

# Modero® Touch Panels

## 5.2" Modero ViewPoint® Wi-Fi Widescreen Touch Panel



The MVP-5150 delivers high-end style and just the right features in a sleek sexy ultra-compact design at a price perfect for any budget. Designed as a low cost alternative to the MVP-5200i, the MVP-5150 is perfect for installations desiring the sleek, sexy design of the MVP-5200i, but do not need all of its features. The MVP-5150 offers both Wi-Fi and one-way IR communication giving the user instant control of virtually any device in the home or office.

#### ULTRA BRIGHT WIDESCREEN DISPLAY

With 800x480 pixel resolution, the MVP-5150 is our brightest touch panel display. Colors are displayed crisply, clearly and accurately. Its 16x9 screen size provides plenty of widescreen multimedia display options.

#### WIRELESS CONVENIENCE AND SECURITY

Fully integrated 802.11b/g wireless communications give users outstanding wireless mobility and total system control. And communications remain secure utilizing network security standards including: WEP, WPA, WPA2, EAP-TLS, EAP-TTLS and PEAP.

#### INCREASED INFRARED CAPABILITY

The MVP-5150 offers a total of ten IR ports: (1) 38kHz AMX port, (1) 455kHz AMX port, and (8) user-defined IR ports for direct communication with 3rd party IR-enabled equipment.

- Ultra-light, compact and thin form factor
- Faster processing and energy efficient
- High-gloss black styling
- Charging options include table charging station (MVP-TCS52) and wall charging station (MVP-WCS52) (kickstand not available)
- Just the right features and just the right price
- (10) IR ports: (1) 38kHz AMX, (1) 455kHz AMX, (8) user IR



**R & B COMPUTER SYSTEMS LTD.**  
力衡電腦系統有限公司

**2749 3325**  [www.rnb.com.hk](http://www.rnb.com.hk)  
 [rnb@rnb.com.hk](mailto:rnb@rnb.com.hk)

Unit 1009, Global Gateway Tower, 63 Wing Hong Street, Cheung Sha Wan, Kln., HK  
香港九龍長沙灣永康街 63 號 Global Gateway Tower 1009 室

### MVP-5150 (FG5966-07)

#### DIMENSIONS (HWD)

4 5/8" x 7 1/2" x 3/4" (11.7 cm x 19.1 cm x 2.0 cm)

#### POWER

110-240VAC +/- 10%, 50/60Hz

#### MINIMUM POWER SUPPLY REQUIRED

PS3.0 Power Supply (FG423-30):

All MVP-5150 models are shipped with this power supply

#### POWER MODES

- ON: All necessary modules are powered up and device remains online with the Netlinx Master.
- STANDBY: LCD/backlight shutdown. Panel resumes the ON mode instantly upon screen touch.
- FULL-OFF: Power to all peripherals and components is turned off. Reboot required to wake.

#### CERTIFICATIONS

- FCC Part 15 Class B and CE
- IEC60950

#### BATTERY DURATION

- 6 hours of continuous use
- 4 days of normal use (25% On, 25% Standby, 50% Off)

#### MEMORY

- 128 MB NAND FLASH
- 256 MB Mobile DDRAM

#### WEIGHT

1.2 lbs (0.6 kg)

#### SCREEN PROPERTIES

- Contrast Ratio: 400:1
- Screen Resolution: 800 x 480 pixels WVGA
- Aspect Ratio: 16 x 9
- Brightness (Luminance): 300 cd/m<sup>2</sup>
- Display Colors: 262,144 colors (18-bit color depth)
- Dot/Pixel Pitch: 180 dpi
- Panel Type: TFT Color Active-Matrix

#### VIEWING ANGLE

+/- 60° (horizontal) and + 80°/- 40° (vertical)

#### OPERATING/STORAGE ENVIRONMENTS

- Operating Temperature: 0° C (32° F) to 40° C (104° F)
- Operating Humidity: 20% - 85% RH
- Storage Temperature: -20° C (-4° F) to 60° C (140° F)
- Storage Humidity: 5% - 85% RH

#### INCLUDED ACCESSORIES

- PS3.0 Power Supply (FG423-30)
- Stylus (pre-installed onto the left side of the unit)
- Integrated battery

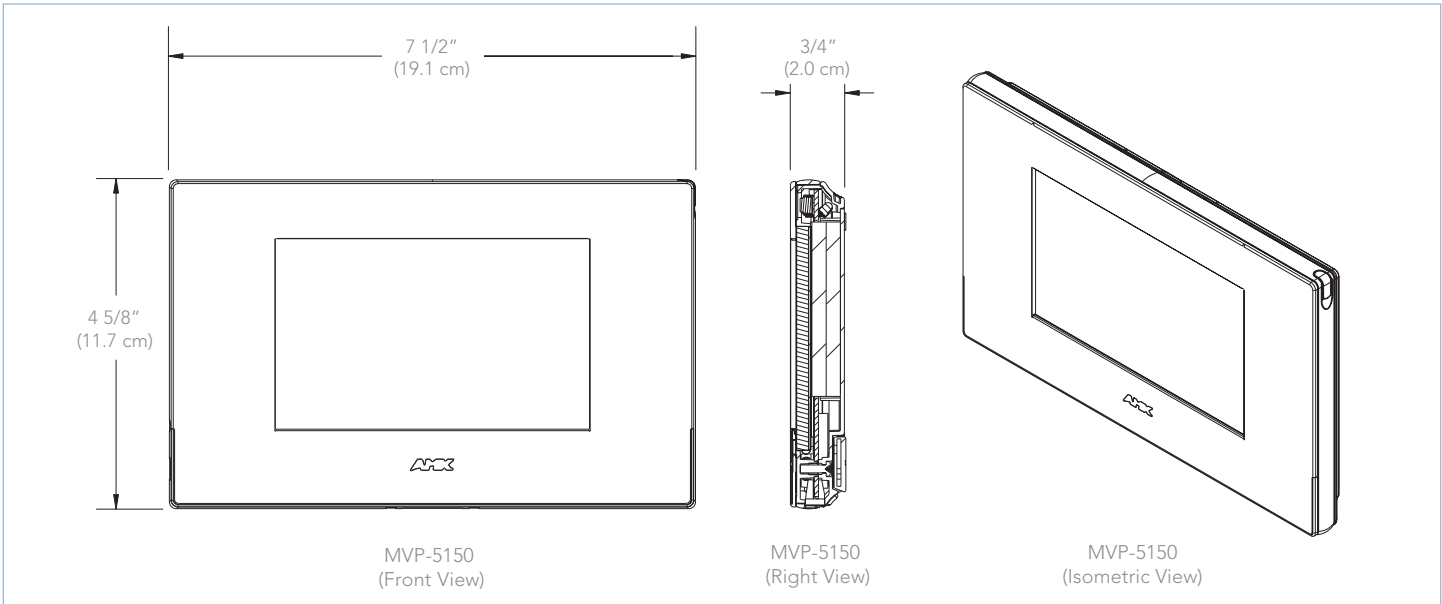

IT'S YOUR WORLD. TAKE CONTROL.